

REFIN2U Series ◊ FLAT PANEL 1AC Power Supply

30W ◊ Input: 100V-277VAC nom. ◊ 2U Width

FEATURES

- 85-305VAC wide-range input
- 2U Width (36mm)
- Push-In connectors
- 30W at -40° to 55°C, globally
- Efficiency 90%; no load power < 100mW
- Hiccup - over current protection; I > 130%
- OVC III to 3000m; OVC II to 5000m altitude
- LPS limited power source
- Mountable in any orientation
- 3 year warranty



93.5 x 35.5 x 58.5mm (3.7 x 1.4 x 2.3 inch)
151g (0.33 lbs)

APPLICATIONS



SAFETY & EMC



DESCRIPTION

REFIN2U-S30: With an output of 30 watts, this power supply represents the entry-level model of the 2U (36mm) width step-shape DIN-rail AC/DC power-supply series for “flat-panel” distribution boards in home automation systems. Electrical connections for solid or stranded wires can be made using spring-loaded push-in terminals, without the need for ferrules or tools. Thanks to rear mounting flaps, the modules can also be installed on a back panel in any orientation, even without a DIN rail.

Further information on alternative modules with output ratings of up to 90 watts in the same 2U (36 mm) width can be found on the product page: REFIN2U-S.

SELECTION GUIDE

Part Number	Input Voltage Range [VAC]	Output Voltage [VDC]	Adjustable Output Voltage [VDC]	Output Current nom. [mA]	Efficiency ⁽¹⁾ typ. [%]	Output Power continuous [W]
REFIN2U-S30/12	85-305	12	10.8-13.2	2500	90	30
REFIN2U-S30/24	85-305	24	21.6-26.4	1250	89	30

Note1: Efficiency is tested at 230VAC and full load at +25°C ambient

REFIN2U Series ◊ FLAT PANEL 1AC Power Supply

30W ◊ Input: 100V-277VAC nom. ◊ 2U Width

Model Numbering



BASIC CHARACTERISTICS (measured @ $T_{AMB}= 25^{\circ}C$, nom. V_{IN} , full load and after warm-up unless otherwise stated)

Parameter	Condition	Min.	Typ.	Max.
Nominal Input Voltage	50/60Hz	100VAC		277VAC
Operating Range ⁽²⁾	47-63Hz	85VAC		305VAC
Input Current				0.65A
Inrush Current	cold start at 25°C	$V_{IN}= 100VAC$		20A
		$V_{IN}= 230VAC$		25A
		$V_{IN}= 277VAC$		60A
No Load Power Consumption	$V_{IN}= 230VAC$			100mW
Ecodesign Standby Mode Use (Available output power for stated input power)	$P_{IN}= 0.3W$			200mW
	$P_{IN}= 0.5W$			390mW
	$P_{IN}= 0.8W$			650mW
Input Frequency Range		47Hz		63Hz
Output Voltage Adjustability ⁽³⁾	potentiometer	REFIN2U-S30/12; set point $V_{OUT} = 12VDC$	10.8VDC	13.2VDC
		REFIN2U-S30/24; set point $V_{OUT} = 24VDC$	21.6VDC	26.4VDC
Minimum Load		0%		
Power Factor	$V_{IN}= 100-120VAC$		0.6	
	$V_{IN}= 200-277VAC$		0.45	
Start-up time			400ms	1s
Rise time			10ms	25ms
Hold-up time	$V_{IN}= 230VAC$	25ms	45ms	
Internal Operating Frequency			130kHz	
Output Ripple and Noise ⁽⁴⁾	20MHz BW			1% of Vout

Note2: The products were submitted to all safety files at AC-operation (100-277VAC ±10% tolerance)

Note3: Make sure that the maximum rated output power will not be exceeded when trimming up.

Note4: Measurements are made with a 0.1µF MLCC & 10µF E-cap in parallel across output (low ESR)

The test setup can have an impact on ripple noise values (placement of scope probe, capacitors, it's specifications, wires, PCB tracks, distances, etc.)

Efficiency vs Output Power

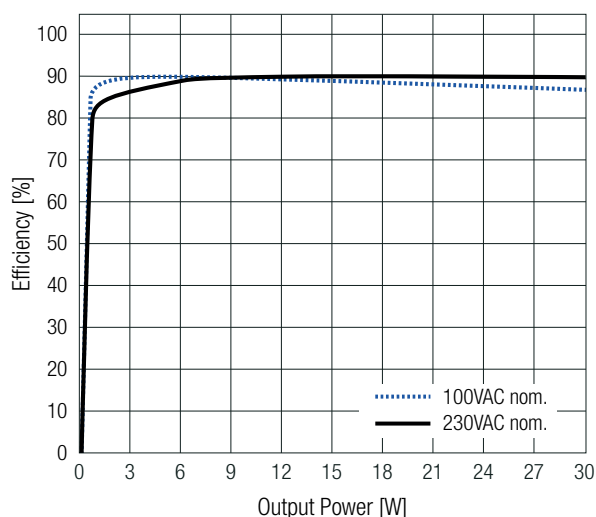

Power Dissipation vs. Output Power

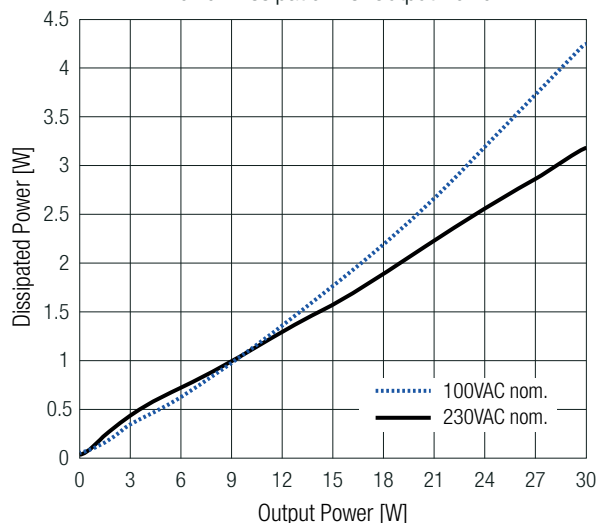

REFIN2U Series \diamond FLAT PANEL 1AC Power Supply

30W \diamond Input: 100V-277VAC nom. \diamond 2U Width



REGULATIONS (measured @ $T_{AMB}=25^{\circ}\text{C}$, nom. V_{IN} , full load and after warm-up unless otherwise stated)

Parameter	Condition	Value
Output Accuracy		$\pm 3.0\%$ max.
Line Regulation	low line to high line, full load	$\pm 0.1\%$ max.
Load Regulation ⁽⁵⁾	10% to 100% load	$\pm 0.5\%$ max.
Transient Response	25% load step change	800mV max.
	recovery time	3ms max.

Note5: Operation below 10% load will not harm the converter, but specifications may not be met

PROTECTIONS (measured @ $T_{AMB}=25^{\circ}\text{C}$, nom. V_{IN} , full load and after warm-up unless otherwise stated)

Parameter	Type	Value
Input Fuse	internal	T3.15A, slow blow type
Short Circuit Protection (SCP)	below 100m Ω	hiccup mode; auto recovery
Over Current Protection (OCP)		130-200%, hiccup mode
Over Voltage Protection (OVP)	REFIN2U-S30/12	17VDC, hiccup mode
	REFIN2U-S30/24	30VDC, hiccup mode
Over Voltage Category (OVC)	according to 62368-1	OVC II (5000m)
		OVC III (3000m)
DC ON LED		green: output voltage present
Class of Equipment		Class II
Isolation Voltage	1 minute	according to 62368-1
Isolation Resistance	I/P to O/P	$V_{ISO} = 500\text{VDC}$
Isolation Capacitance		100kHz/0.1V
Insulation Grade	I/P to O/P	reinforced

ENVIRONMENTAL (measured @ $T_{AMB}=25^{\circ}\text{C}$, nom. V_{IN} , full load and after warm-up unless otherwise stated)

Parameter	Condition	Value
Operating Ambient Temperature Range	@ natural convection (0.1m/s), refer to „Derating Graph“	-40°C to +90°C
Maximum Case Temperature		+95°C
Operating Altitude ⁽⁶⁾	according to 62368-1, refer to „Altitude Derating“	5000m (OVC II)
		3000m (OVC III)
Operating Humidity	non-condensing	95% RH max.
Pollution Degree		PD2
IP Rating		IP20
Shock	according to IEC 60068-2-27 Fa, non-operating	15G/11ms, 3 times (positive/negative) in all axis
Vibration	according to IEC 60068-2-6 Fc, non-operating	5 - 8.4Hz @ 3.5mm deflection 8.4 - 150Hz @ 2G, 10 cycles /axis(min-max-min); 1 octave/min
MTBF	$T_{AMB} = +40^{\circ}\text{C}$	1000 x 10 ³ hours
Design Lifetime	full load	$T_{AMB} = +40^{\circ}\text{C}$
		$T_{AMB} = +60^{\circ}\text{C}$

Note6: Recognized by safety agency for safe operation up to 5000m. High altitude operation may impact the performance and lifetime. Please contact RECOM tech support for advice

REFIN2U Series ◊ FLAT PANEL 1AC Power Supply

30W ◊ Input: 100V-277VAC nom. ◊ 2U Width



ENVIRONMENTAL (measured @ $T_{AMB} = 25^{\circ}C$, nom. V_{IN} , full load and after warm-up unless otherwise stated)

Derating Graph ⁽⁷⁾

(@ Chamber, standard orientation and natural convection 0.1m/s)

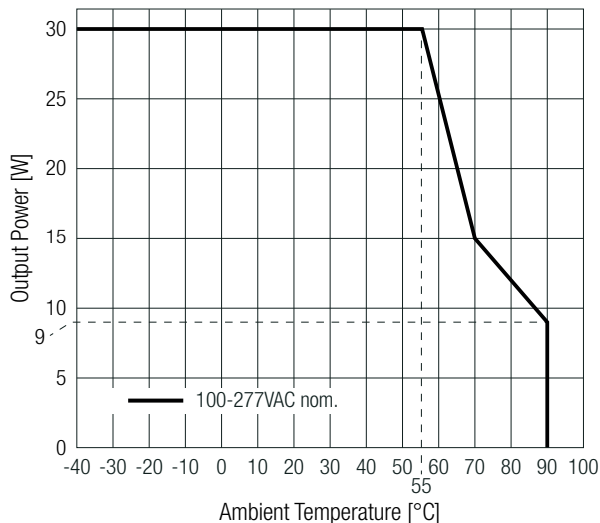

Altitude Derating

(for continuous operation)

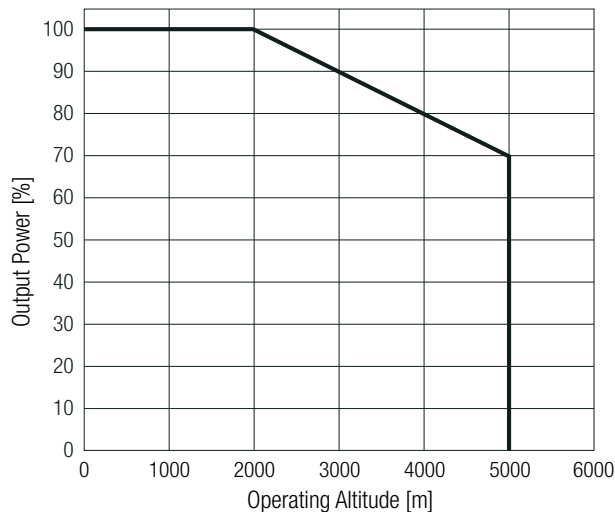

Note7: VAC nom. values include ±10% tolerance

SAFETY & CERTIFICATIONS

Certificate Type (Safety)	Report Number	Standard
Audio/Video, information and communication technology equipment - Part1: Safety requirements 3rd Edition	E491408-A6033-UL	UL62368-1:2021 3rd Edition CAN/CSA-C22.2 No. 62368-1-19 3rd Edition
Audio/Video, information and communication technology equipment - Part1: Safety requirements 3rd Edition (CB Scheme)	250429012	IEC62368-1:2018 3rd Edition
Audio/Video, information and communication technology equipment - Part1: Safety requirements 3rd Edition		EN IEC 62368-1:2020+A11:2020
RoHS2		RoHS 2011/65/EU + AM2015/863

EMC Compliance	Condition	Standard / Criterion
Low voltage power supplies, d.c. output Part 3: Electromagnetic compatibility		EN IEC 61204-3:2018, Class B
ESD Electrostatic discharge immunity test	Air: ±2, 4, 8kV Contact: ±4kV	IEC61000-4-2:2008, Criteria A EN61000-4-2:2009, Criteria A
Radiated, radio-frequency, electromagnetic field immunity test	10V/m (80-1000MHz), 3V/m (1400-2000MHz), 1V/m (2000-2700MHz)	IEC/EN61000-4-3:2006 + A2:2010, Criteria A
Fast Transient and Burst Immunity	AC Power Port L, N, L-N: ±2kV	IEC/EN61000-4-4:2012, Criteria A
Surge Immunity	AC Port: L-N: ±0.5, 1, 2kV L-PE, N-PE: ±1, 2, 4kV	IEC/EN61000-4-5:2014 + A1:2017, Criteria A
Immunity to conducted disturbances, induced by radio-frequency fields	10Vrms (0.15-80MHz)	IEC61000-4-6:2013, Criteria A EN61000-4-6:2014, Criteria A
Power Magnetic Field Immunity	30A/m	IEC61000-4-8:2009, Criteria A EN61000-4-8:2010, Criteria A
Voltage Dips	100%: 0.5P, 1P 60%, 30%, 20%	IEC/EN61000-4-11:2004+A1:2017, Criteria A
Voltage Interruptions	100%	IEC/EN61000-4-11:2004+A1:2017, Criteria B
Limits of Voltage Fluctuations & Flicker		EN61000-3-3:2013+A1:2019

EMC Compliance according to EN55032	Condition	Standard / Criterion
Electromagnetic compatibility of multimedia equipment – Emission Requirements		EN55032:2015+A11:2020, Class B

REFIN2U Series ◊ FLAT PANEL 1AC Power Supply

30W ◊ Input: 100V-277VAC nom. ◊ 2U Width

DIMENSION & PHYSICAL CHARACTERISTICS

Parameter	Type	Value
Materials	case/baseplate	polycarbonate, (UL94 V-0)
	potting	PU, (UL94 V-0)
	PCB	FR4, (UL94 V-0)
Dimension (HxWxD)		93.5 x 35.5 x 58.5mm 3.7 x 1.4 x 2.3 inch
Weight		151g typ. 0.33 lbs

Dimension Drawing (mm)

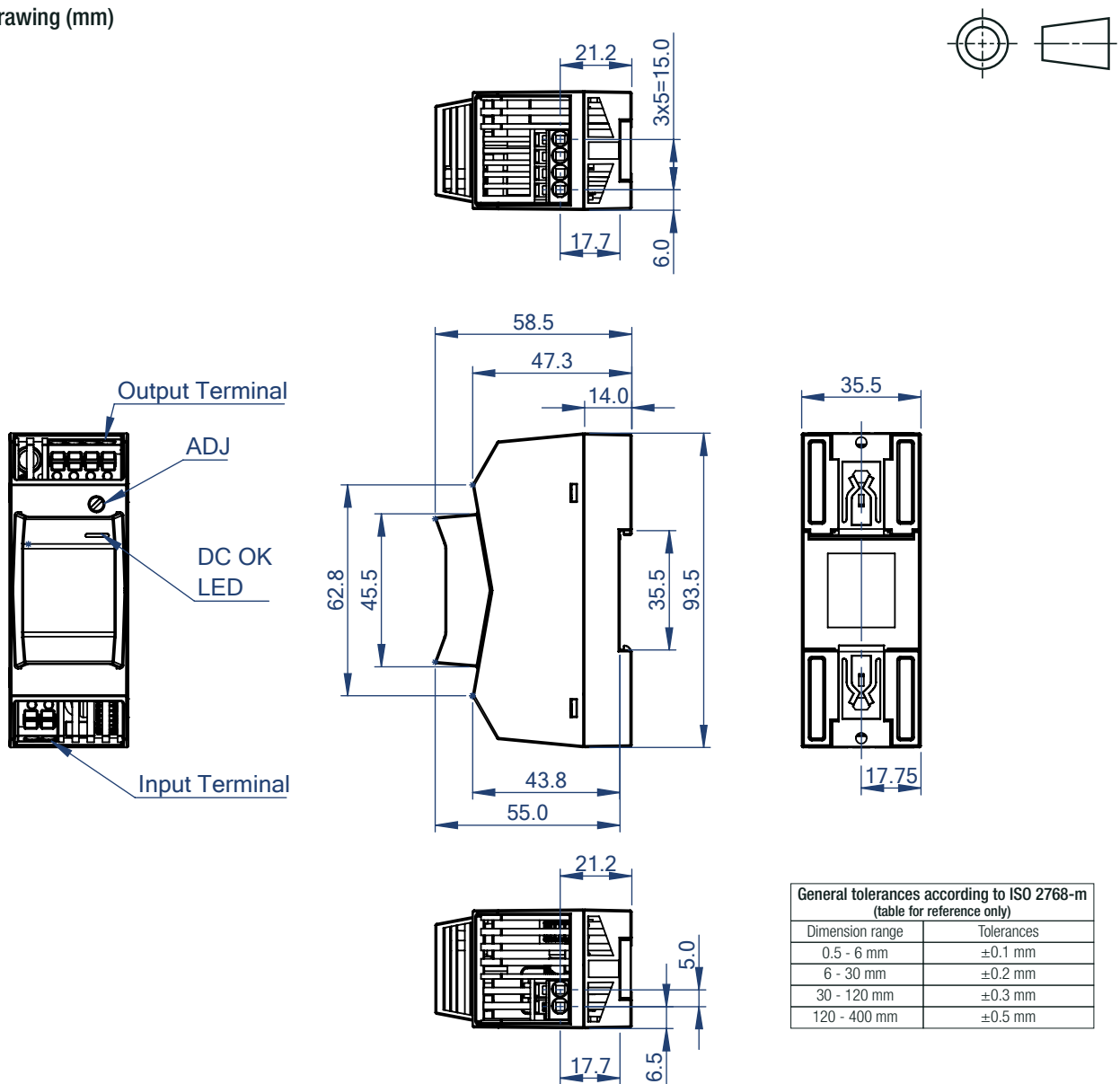

Dimension range	Tolerances
0.5 - 6 mm	±0.1 mm
6 - 30 mm	±0.2 mm
30 - 120 mm	±0.3 mm
120 - 400 mm	±0.5 mm

DETAIL A
Input Terminal

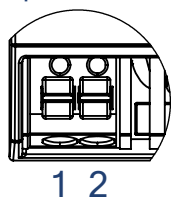

DETAIL B
Output Terminal

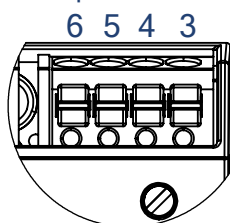

Push-In Terminal Information [®]

#	Function	AWG	mm ²
1	VAC _N N	20-12	0.2-2.5
2	VAC _N L	20-12	0.2-2.5
3, 4	-Vout	20-12	0.2-2.5
5, 6	+Vout	20-12	0.2-2.5

Wire stripping length: 10-11mm

Note8: Use flexible (stranded wire) or solid cables with above wire cross-section is recommended.
Ferrules are recommended for flexible cables. Use copper conductors designed for an operating temperature of at least 90°C.

INSTALLATION & APPLICATION

Mounting Instruction

Mounting Rail: Standard TS35 DIN Rail in accordance with EN 60715.

Mounting

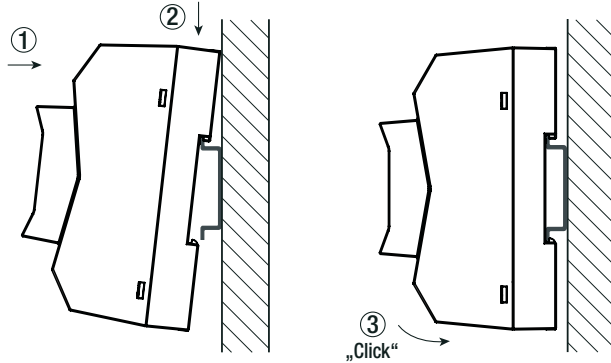

1. Place the device on the DIN rail with a slight upward tilt. Snap the device into the DIN rail.
2. Now tilt the device downwards until it reaches the lower part of the rail.
3. Press the lower part of the device firmly against the rail until the device locks into position on the DIN rail. "Click"
4. To make sure it is securely locked in place, give the device a gentle shake.

Release

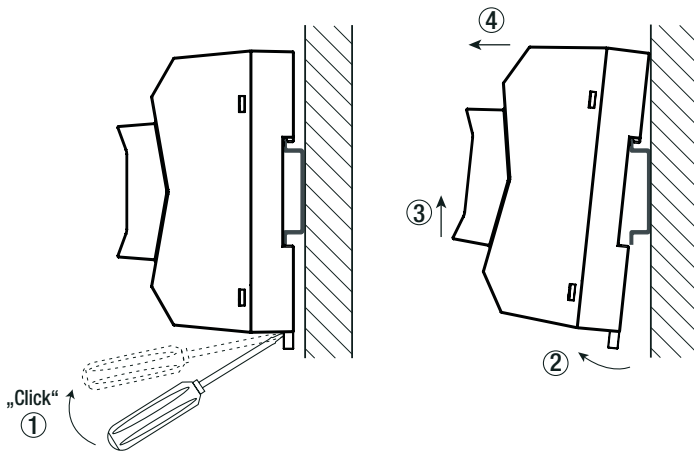

1. Pull the DIN rail latch by using a screwdriver OUT of the device and until it locks in position.
2. Tilt the bottom of the device OUT.
3. Pull the device away from the DIN rail by pushing it up.
4. Remove the power supply completely from the rail.

Mounting Instruction with extended mounting flanges

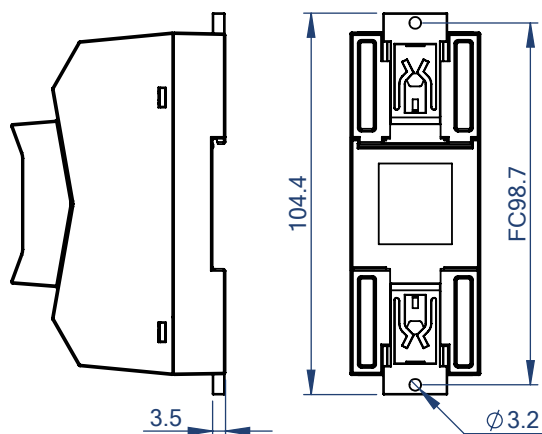

1. Press the mounting flanges out of the housing until they click into position.
2. Secure the device to the mounting surface using two M3 screws. Use cylinder head screws only. Countersunk screws are not permitted. Recommended tightening torque= 0.5Nm
3. To ensure that it is securely attached to the mounting surface, shake the device gently.

INSTALLATION & APPLICATION

Installation Instructions

To guarantee sufficient convection cooling, keep a distance of 30mm above and below the device.

The device should be installed with the input side down (standard orientation).

For modules horizontally wall-mounted or upside down, the output power must be reduced to 90% of the specified rated power.

The modules can be placed directly next to each other.

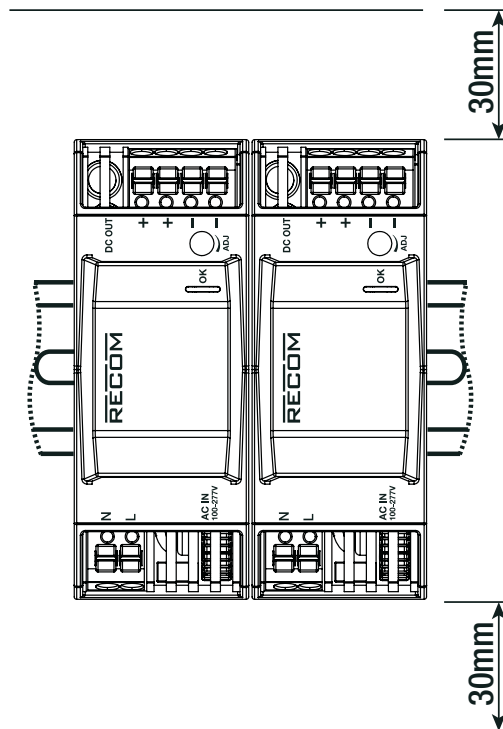

Series Operation

- 1) Only use PSU with the same type and performance class with identical parameters.
- 2) To increase the DC output voltage, connect 2 or more power supply units in series. See below table/figures as example.
- 3) **ATTENTION:** If the power supply units are connected in series, the permanently permissible SELV voltage of max. DC 60V is not guaranteed. Leakage current, EMI, inrush current, harmonics will increase when using multiple power supplies.

Example with 2 PSU's in series:	Figure 1	Figure 2	Figure 3
REFIN2U-S30/12	+24Vdc	-24Vdc	± 12 Vdc
REFIN2U-S30/24	+48Vdc	-48Vdc	± 24 Vdc

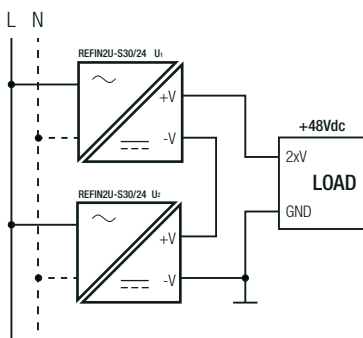

Figure 1

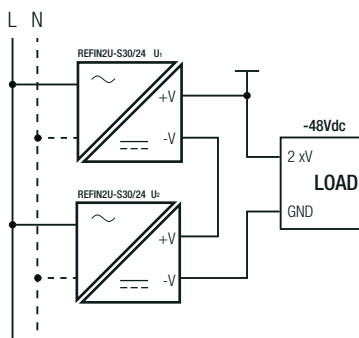

Figure 2

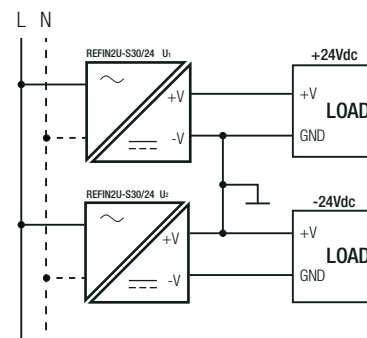
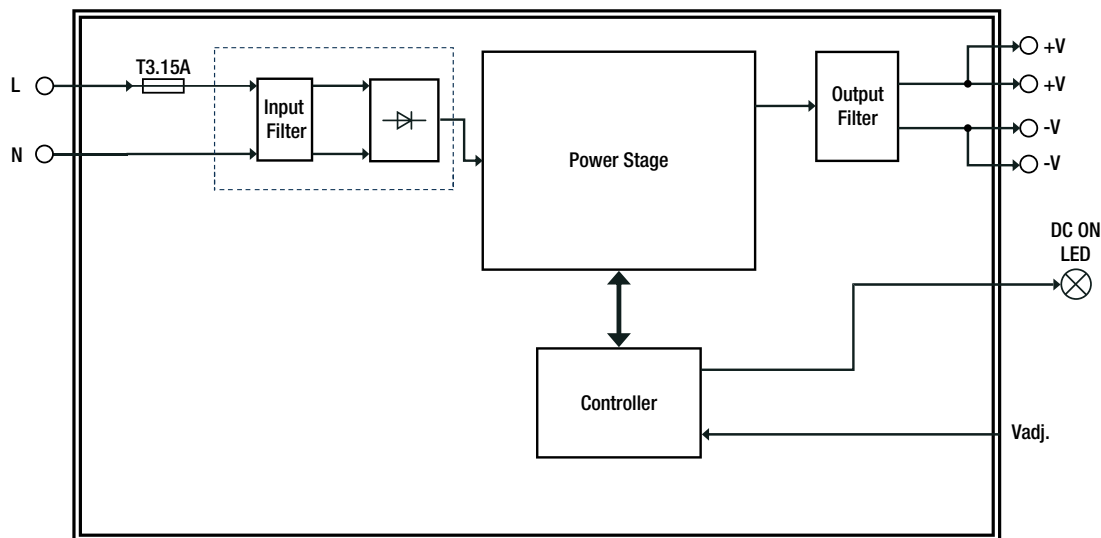

Figure 3

REFIN2U Series ◊ FLAT PANEL 1AC Power Supply

30W ◊ Input: 100V-277VAC nom. ◊ 2U Width

BLOCK DIAGRAM



PACKAGING INFORMATION

Parameter	Type	Value
Packaging Dimension (LxWxH)	cardboard box	300.0 x 200.0 x 270.0mm
Packaging Quantity		30 pcs
Storage Temperature Range		-40°C to +85°C
Storage Humidity	non-condensing	95% RH max.

The product information and specifications may be subject to changes even without prior written notice. The product has been designed for various applications; its suitability lies in the responsibility of each customer. The products are not authorized for use in safety-critical applications without RECOM's explicit written consent. A safety-critical application is an application where a failure may reasonably be expected to endanger or cause loss of life, inflict bodily harm or damage property. The applicant shall indemnify and hold harmless RECOM, its affiliated companies and its representatives against any damage claims in connection with the unauthorized use of RECOM products in such safety-critical applications.